

UK Installation instructions**DE** Montageanleitung**CZ** Montážní návod**DK** Monteringsvejledning**EE** Paigaldusjuhend**FI** Asennusohje**FR** Notice de montage**HU** Szerelési útmutató**IT** Istruzioni di montaggio**LT** Montavimo Instrukcijos**LV** Instalācijas instrukcija**NO** Monteringsanvisning**PL** Instrukcja montażu**SE** Installationsanvisning**RU** ИНСТРУКЦИЯ ПО МОНТАЖУ

TYPE : GTLED PRO MS-M-L-XL

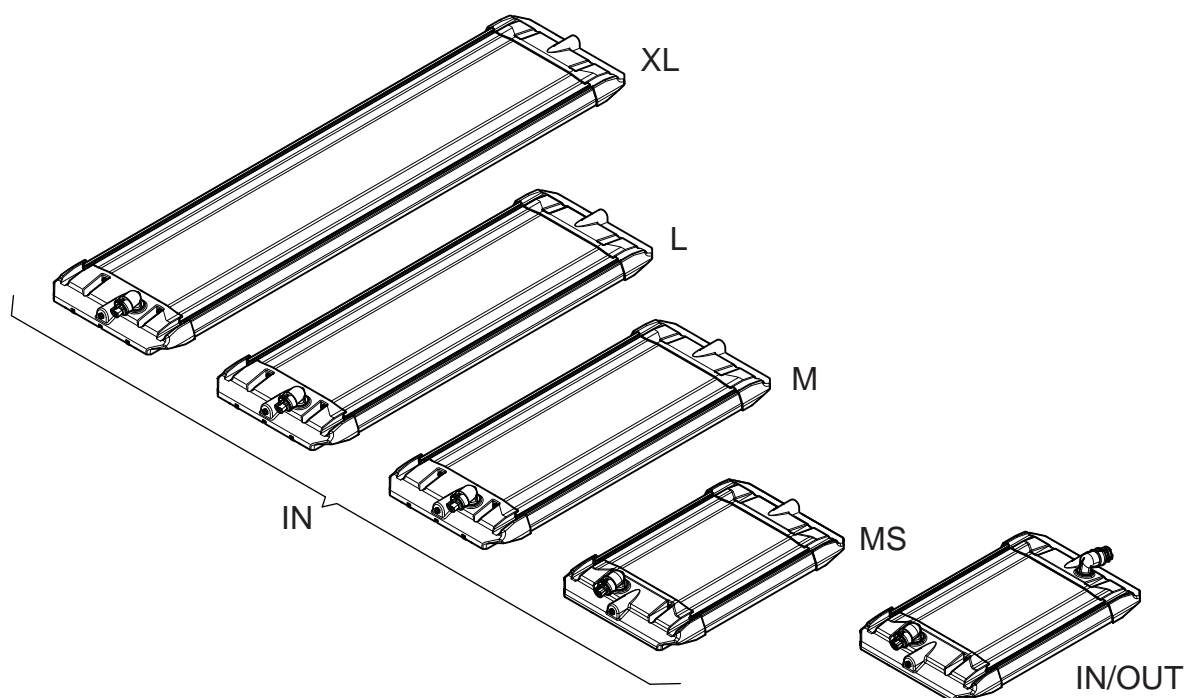

The luminaire should be positioned so that prolonged staring into the luminaire at a distance <2m is not expected



LED CLASS I CLASS II CE IK08 IP66

1

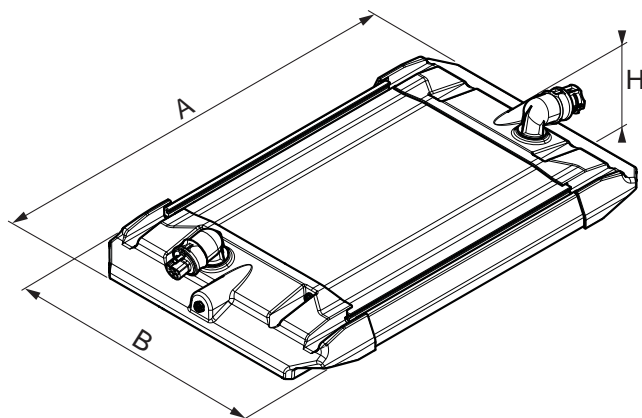

GTLED PRO	A (mm)	B (mm)	H (mm)		
MS	520	313	90	12-48	6,5 kg
M	800	313	90	72	10,0 kg
L	952	313	90	144	12,2 kg
XL	1320	313	90	216	17,2 kg

MS-M-L-XL

263mm

10  8 Nm min
10 Nm max

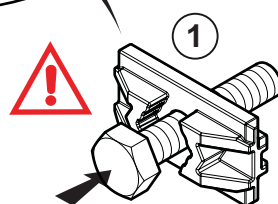
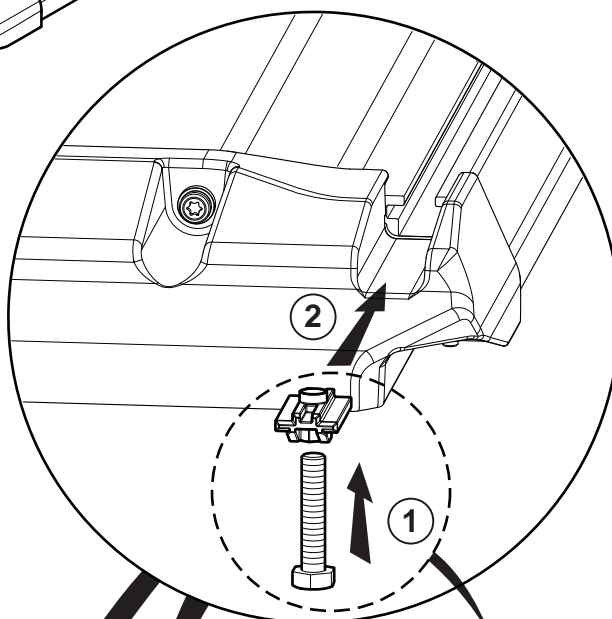
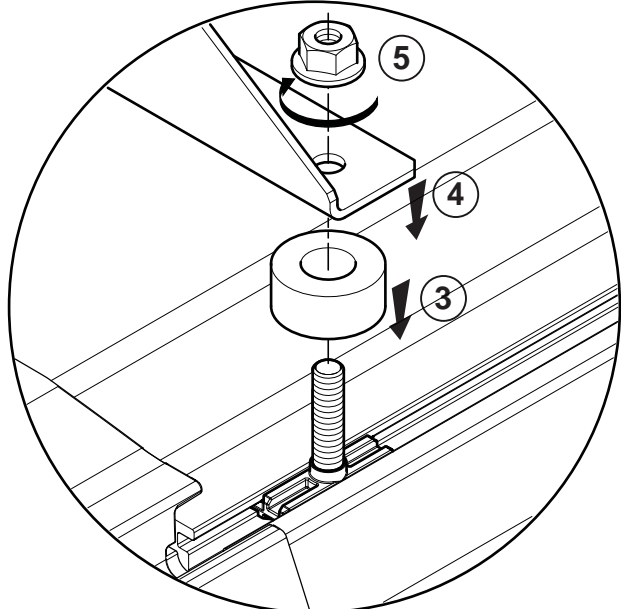

Code 96669609

Code 96631713

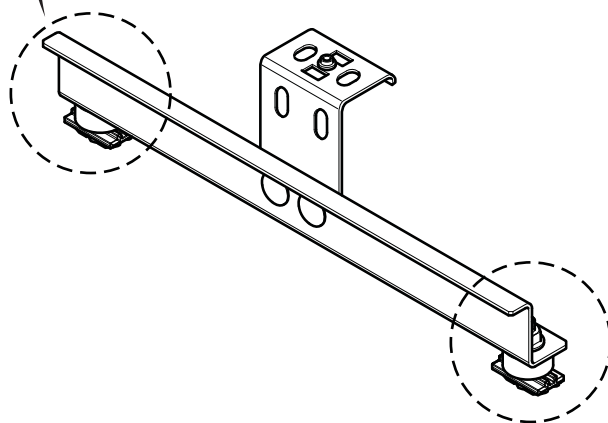
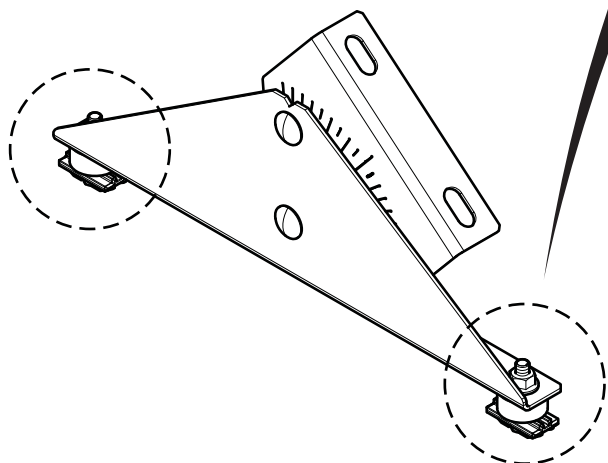

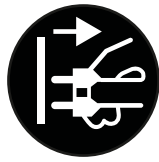

SWITCH OFF POWER BEFORE
CONNECTING FLOODLIGHT

3

IN

MS-M-L-XL



THORN
GP GB GRP

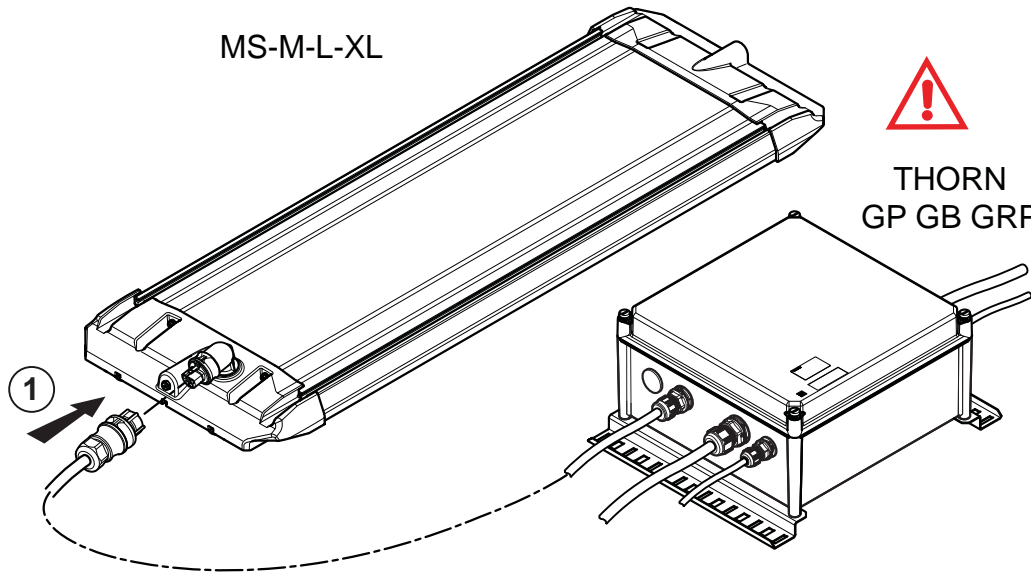

IN / OUT

MS

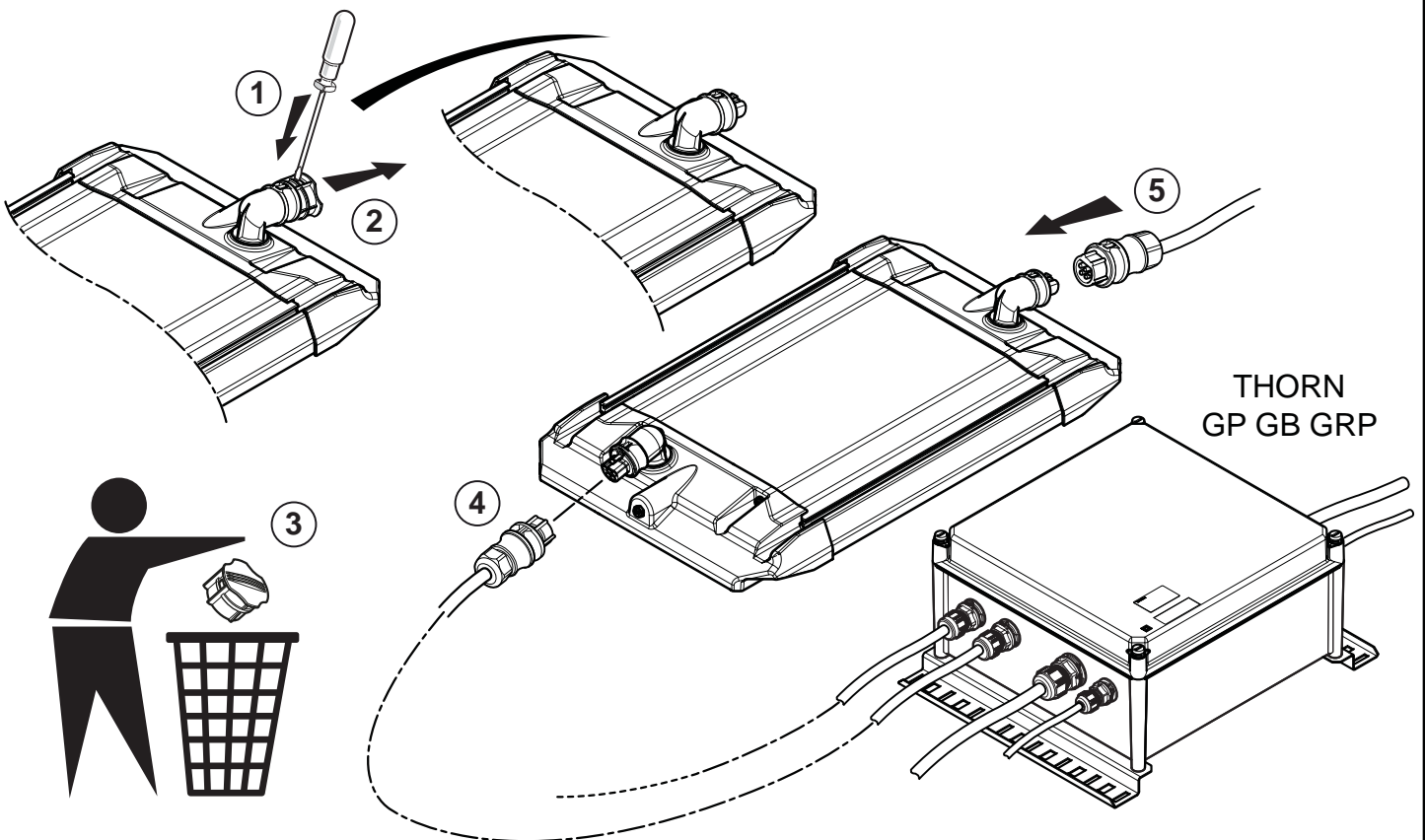

4

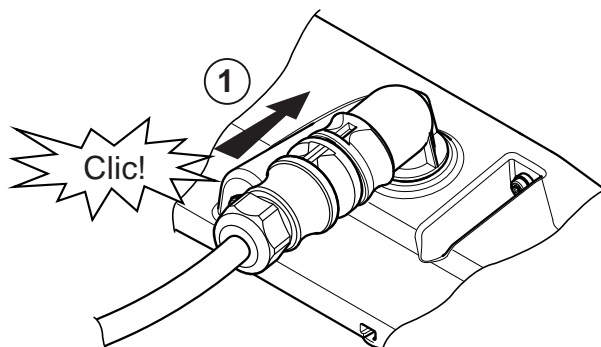

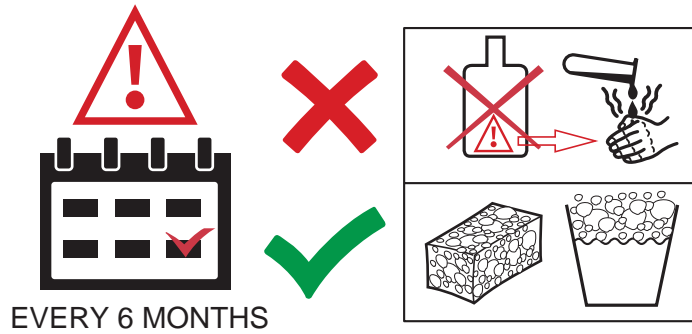

FRANCAIS

-Remplacer toute protection fissurée.
-Les luminaires classe II doivent être installés de façon à ce que la partie métallique ne soit pas en contact avec l'installation électrique connectée à la terre.

ATTENTION: Les luminaires classe I doivent être reliés à la terre.
-Ce luminaire fonctionne à une tension nominale qui doit être coupée avant toute intervention sur l'appareillage.
-Toute modification de cet appareil est interdite.
-Respecter la distance minimale par rapport aux objets éclairés définie par ce sigle.

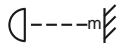

SVERIGE

-Ersätta alla spräckta skyddsplåtar.
-Klass II armaturer måste installeras så att nakna metalldelar i armaturen inte är i kontakt med någon elektrisk installation, kopplad till en skyddledare.

WARNING: Klass I armaturer måste vara jordade.
-Denna armatur fungerar med högspänning som måste vara frånslagen före ingripande i driftdonen.
-Alla ändringar i denna armatur är förbjuden.

ITALIANO

-Sostituire sempre tutte le protezioni danneggiate.
-Gli apparecchi in classe II devono essere installati in modo che le parti metalliche non siano in contatto con apparati elettrici collegati a terra.
ATTENZIONE: Gli apparecchi in class I devono essere collegati a terra.
-Questo apparecchio funziona a tensione nominale, questa deve essere interrotta prima di ogni intervento sul gruppo di alimentazione.
-Ogni modifica dell' apparecchio è proibita.

ENGLISH

-Replace any cracked protective shield.
-Class II luminaires must be installed so that exposed metal work of the luminaire is not in contact with any part of the electrical installation connected to a protective conductor.
WARNING: Class I luminaires must be earthed.
-This luminaire operates at mains voltage which must be switched off before intervention in control gear.
-Any modification to this luminaire is forbidden.
-Lighted objects nearer than the minimal distance in the is forbidden.

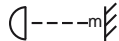

DEUTSCH

-Ersetze jede gebrochene Schutzscheibe.
-Schutzklasse II Leuchten müssen so installiert werden, daß berührbare Metallteile nicht mit einem, an dem Schutzleiter angeschlossenen Teil der elektrischen Installation in Kontakt kommen können.
ACHTUNG: Schutzklasse I Leuchten müssen geerdet sein.
-Diese Leuchte wird mit Netzspannung betrieben. Bevor Eingriffe am Vorschaltgerät vorgenommen werden sowie vor Wartung und Installation, ist die Versorgungsspannung abzuschalten.
-Jede Änderung an dieser Leuchte ist verboten.

SUOMI

-Rikkoontunut suojalasi vaihdettava välittömästi uuteen vastaavaan.
-Asennettaessa suojausluokan II valaisinta on peruseristetyin johdon ja kosketeltavien metalliosien välinen kosketus tehokkaasti eristettävä.
VAROITUS: Suojausluokan I valaisin täytyy maadoittaa.
-Verkköjännite on kytkettävä pois ennen valaisimen huoltotoimenpiteitä.
-Valaisimen rakennetta ei saa muuttaa.