

SPECIFICATION

76MM TOP DIAMETER  
76MM SHAFT DIAMETER  
135MM BASE COLUMN  
6063 ALUMINIUM ALLOY  
STANDARD MACHINE BRUSHED FINISH  
DUAL DOOR LOCKS  
EARTH PIN IN DOOR  
HARDWOOD BACKBOARD  
STANDARD REINFORCEMENT TUBE  
THERMOPLAST ROOT PROTECTION  
COLUMN BASE PROTECTOR  
MODERN TOWN EMBELISHMENT

ALL DIMENSIONS IN MILIMETERS

POST TOP MOUNTED LANTERNS ONLY

MASS : 14.1Kg

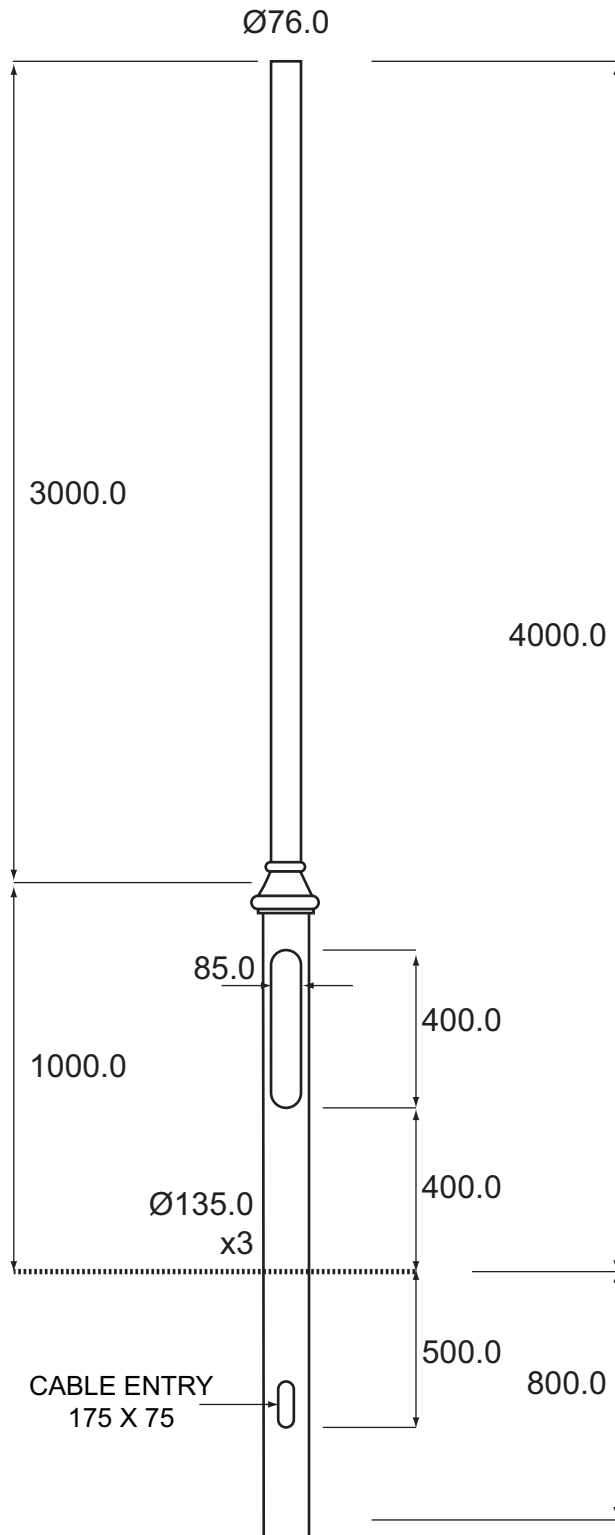

THORN 4M 135 BASE CITYSCAPE  
COLUMN

**THORN**

SAP : 96227923

OLD CAT CODE : QCMT4.76/76