

THORN

LIGHTING



BRAND NEW

PRODUCT FOCUS EDITION 1/2018

member of zumtobel group

BRAND NEW PRODUCTS

INDOOR

OUTDOOR

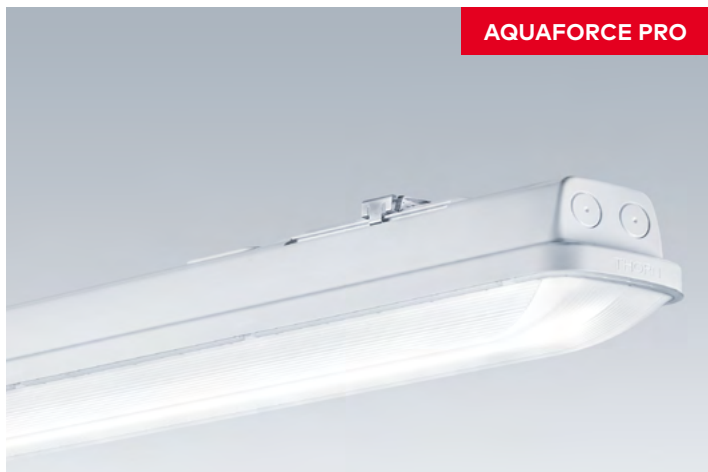

Beginning of 2018 we're setting fresh standards for moisture-proof and dust-resistant LED lighting. Performance and versatility reach new heights with our Aquaforce Pro luminaire, while our brand-new Flow family takes outdoor lighting to the next level in terms of flexibility. The modular design of Flow makes it easy to provide the same look for different city spaces, empowering designers to achieve consistency and visual harmony in both new and retro-fit projects. The new robust high-performance LED street lantern Isaro Pro looks great on any road – and is also fit for the future. The outdoor portfolio will also be extended by EP445 an LED street lantern with that blends into historic cities and towns. Alternatively, EP445 offers the best of both worlds for those wanting to combine modern lighting technology with a more traditional look.

And, as always, we continue to update and improve our existing products to ensure the best possible performance. For details of all the latest additions to the Thorn range, please read on.



AQUA



Building on the success of Thorn's market-leading moisture proof luminaire, Aquaforce Pro sets a new standard for moisture and dust-resistant LED lighting.

FORCE PRO



When it comes to luminaires that can handle damp and dusty conditions, the name of Thorn Aquaforce is already well known. With the brand-new Aquaforce Pro, performance and versatility have reached new heights. The IP66-rated fitting is available in a choice of wide- and medium-beam light distribution options tailored for factory and warehouse settings or car parks – and is ready for the new DIN 67528 parking standard. Its opal diffuser ensures the best light quality. Aquaforce Pro features DALI dimming and a built-in corridor function, using a presence/absence detector to dim down and turn off automatically when circulation areas are not in use. Thanks to the RF radio module, Aquaforce Pro luminaires

are able to connect wirelessly to each other to form groups. This robust luminaire is built to resist ambient temperatures ranging from -20°C to 35°C , and its clever drip-edge design avoids dust depositing on the light output surface. Some LED luminaires still struggle to match the light output of conventional products on a one-for-one basis. But Aquaforce Pro comes in an 8000 lm version, powerful enough to serve as a direct one-for-one replacement for 2x58 W or 2x49 W conventional luminaires, making it an ideal choice for retrofit and refurbishment projects. And with efficacy as high as 141 lm/W, the potential savings are significant.





EP 445

With historic style and cutting-edge lighting technology, EP445 brings you the very best of both worlds.

Thorn's EP445 combines a 19th-century look with 21st-century performance. This retro-style lantern is the perfect choice for replacing traditional lighting in historic locations and conservation areas with a durable, energy-efficient and modern solution. EP445 features an automatic disconnection to prevent electrical damage when the lantern is opened, and 10kV surge protection. Three different levels of current can be selected on the driver, for on-site adjustment. And this robust lantern is designed to withstand the

elements – it's rated IP66 for protection against dust and moisture, and IK08 for impact resistance. With efficacy of 122 lm/W and a 100 000-hour lifetime, EP445 is a particularly attractive choice for retrofit and refurbishment projects where energy saving is a priority. This is reinforced by integrated Bi-Power setups, which can be very easily adapted. EP445 offers a post-top and suspended versions, accessories for use with a variety of supports, and a wide choice of light distributions.

FLOW



Our most versatile outdoor solution yet, Flow integrates seamlessly into any urban setting, allowing designers to create a unified look.



As people flow through the city by car, bike or on foot, Flow creates light that flows with them, adapting and providing safety and high visual performance, while creating a pleasant and welcoming ambience. Flow fits in everywhere, providing the most efficient distribution for all kinds of urban activities – whether it's jogging, driving, shopping or socialising. The timeless, understated design language of this brand new luminaire makes it easy to picture in setting. But it's not only Flow's appearance that makes it so flexible. The luminaire features 6 different mounting variants, 13 optical possibilities for street lighting and area lighting, a choice of tilting options (negative and positive) and dimming options to contribute to comfort and wellbeing in large and small roads, residential areas, city centres, car parks, footpaths, train platforms, education and sports institutions, industrial buildings and open areas. Compatible with most of radio frequency systems on the market, Flow also brings intelligence to urban spaces through a wide choice of control options, including DALI, bi-power, power-line or wireless control (InCity) and presence detection. This enables energy savings while improving safety and contributing to a sense of wellbeing by adapting to movements of pedestrians, cyclists and cars. Flow offers high-performance photometry optimised for each specific application. Its efficacy reaches 139 lm/W, enabling it to save significant amounts of energy compared to conventional solutions, and it comes with a 10 kV surge protection device as standard. Lumen packages ranging from 1700 lm to 13600 lm are available.





ISARO PRO

This robust and high-performance LED street lantern brings comfort and safety to any road or street.

Pressure to reduce energy costs and carbon emissions for outdoor lighting is stronger than ever. High-quality LED street lanterns offer a great solution, thanks to clever design, highly efficient light sources, long life and smart controls. Made of top-quality alloy, Isaro Pro is built to withstand all conditions, and to cope with physical impact and vibration. With a lifetime of up to 100 000 hours, it guarantees years of reliable performance, ensuring a low-cost of ownership. And with connectivity built in, it's a truly futureproof solution. As well

as being robust, this modern lantern is slim, sleek and performs brilliantly. With light output of up to 9500 lm for the first size launched, Isaro Pro size S is powerful enough to handle streets, residential areas and car parks. Because every street is different, Isaro Pro uses Thorn's unique R-PEC[®] optic to offer unprecedented optical flexibility. A choice of 14 precise light distributions is available for highly efficient and comfortable light, exactly where it is needed, whether lighting a residential street, a busy road or a pedestrian crossing.

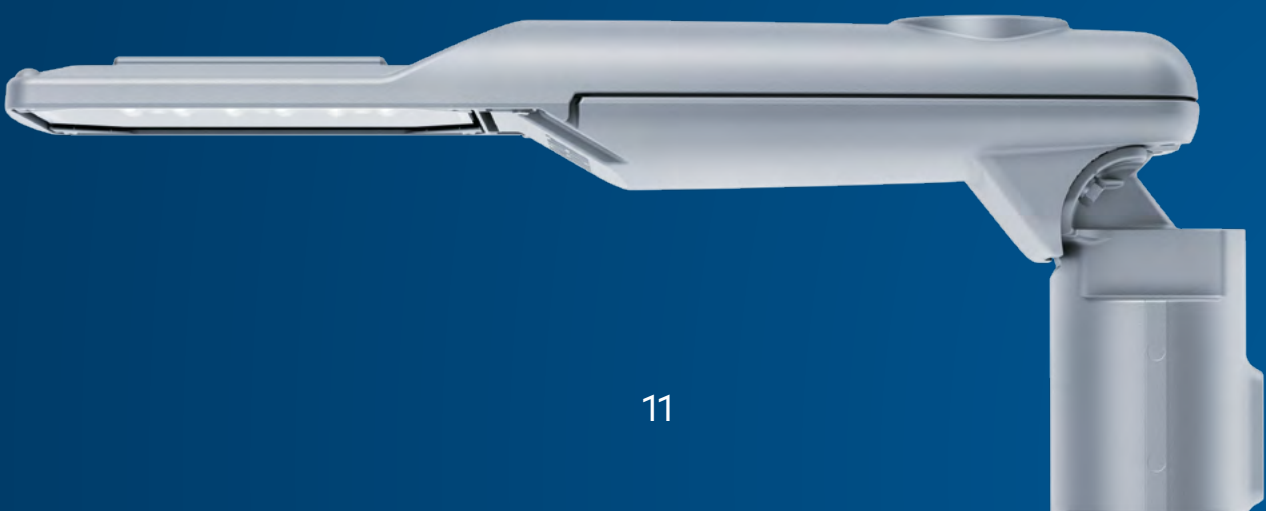

PRODUCT UPGRADES



THORNLIGHTING.COM/POPL

POPPACK

A classic that remains as popular as ever, the latest Thorn PopPack provides enhanced flexibility.

PopPack is the perfect one-for-one LED replacement for single and twin fluorescent battens, enabling big savings on energy and maintenance. It's suitable for refurbishment and new installations, with a choice of three lengths and eight lumen outputs of up to 11000 lm. With a DALI dimmable version available and PIR sensors, further savings can be achieved. It's easy to install and align, using the slots in the base tray, either directly on to the surface or using a BESA box. PopPack's multiple rear cable entries and knock-out side cable entries ensure simple electrical connection and it is suitable for through-wiring. PopPack features a built-in three-hour emergency function.



THORNLIGHTING.COM/ESCT

ESCORT LED

A robust, durable and easy-to-install bulkhead featuring IK10 and IP65 ingress protection.

Escort LED is a true "fit and forget" bulkhead. With a die-cast aluminium housing, a tough polycarbonate diffuser and vandal-resistant screws, Escort LED is rated to IK10 for impact resistance and IP65 for protection against dust and moisture. Its design accommodates rear cable entry with pre-installed grommets, or side entry with pre-installed cable glands, for easy installation. The installer can select between lumen outputs of 800 or 1000 lm via an easy to use selection switch located on the gear tray.



THORNLIGHTING.COM/FPAK

FLEXPAK

The new narrow beam optic for Thorn's FlexPak high bay provides perfect illumination in logistics applications.

Thorn's FlexPak high bay now features a narrow beam optic for uniform illumination in logistics applications. The optic allows this distinctive ring-shaped luminaire to cast a rectangular light distribution. FlexPak provides up to 31500 lm at 4000 K, with a colour-rendering index (CRI) of 80. Its efficacy is up to 135 lm/W and it is rated IP65 for protection against dust and moisture. This enables big energy savings to be made in logistics warehouses, especially when combined with remote wireless sensors. FlexPak's round design and single-point mounting makes it easy to install with plug-and-play connection. It is available with a constant lumen output feature that keeps light levels the same throughout its lifetime. The new narrow beam option complements the existing wide and very wide beam light distributions and is available for lumen packages from 17000 lm to 31500 lm.



THORNLIGHTING.COM/FPAK

FLEXPAK EMERGENCY LIGHTING KIT

Add emergency lighting functionality to our innovative high bay.

The FlexPak emergency lighting kit makes it easy to add emergency lighting functionality to Thorn's innovative LED high bay. The kit can be purchased together with FlexPak, or installed later as needed. The luminaire has an emergency connector as standard, so installation is a simple matter of plug-and-play. The kit provides 3 hours of continuous lighting in the event of a loss of power, with an optional DALI addressable version. The robust housing of the kit ensures IP65 protection. The emergency lighting kit adds to the flexibility of FlexPak, which is suitable as a direct one-for-one replacement of HID high bay fittings, enabling energy savings of up to 70%. The FlexPak emergency lighting kit is assembled in the UK using high-quality components made in Europe.

PRODUCT UPGRADES



THORNLIGHTING.COM/AFLP

AREAFLOOD PRO

Versatile area floodlight with superior optical performance and control

Thorn's Areaflood Pro is an asymmetrical LED floodlight for general purpose area lighting and sports lighting. The latest version features improved energy efficiency for lower running costs. This high-performance floodlight is available in three sizes with lumen packages up to more than 40000 lm and a choice of five light distributions. Areaflood Pro features excellent control of light, with minimal spill light (0 cd at 90°), ensuring comfort for neighbouring residents. Areaflood offers high levels of protection against dust, moisture and impact (IP66 and IK08) and full controls compatibility. Its compact design and low weight keep costs down for retrofit installations. The product has a rated lifetime of up to 100000 hours covering the drivers and LEDs, meaning little or no maintenance will ever be required.



THORNLIGHTING.COM/ALTA
THORNLIGHTING.COM/ALTS

ALTIS AREA / ALTIS SPORT

With better-than-ever performance, Altis meets and exceeds the lighting needs of sports venues and top arenas.

Our newly upgraded Altis floodlight features improved optics for higher light output of up to 165000 lm, and better thermal management – making the luminaire longer-lasting, more reliable and more efficient. Compared to previous versions, lumen output has been increased by 20% for the symmetric light distribution version and by 25% for the asymmetric version. Designed specifically for sports and large area lighting, Altis provides flicker-free light for super-slow-motion TV filming – even at shooting speeds of up to 1000 frames per second, so it meets the most demanding broadcasting specs for major sports venues. Its slimline IP66-rated driver weighs less than 7 kg, so it's easy to install and maintain, and can be placed remotely up to 200 metres from the luminaire.

THORN

LIGHTING

HONG KONG, TAIWAN

ZG Lighting Hong Kong Ltd.
Unit 503 – 508, 5/F, Building 16W,
Phase 3, Hong Kong Science Park,
New Territories, Hong Kong
T +852/(0)2578 4303
F +852/(0)2887 0247
info.hk@zumtobelgroup.com

MACAU

ZG Lighting Hong Kong Ltd.
Macau Branch
Alameda Dr. Carlos D'Assumpcao,
No. 180, Edificio Tong Nam Ah,
Central Comercio, 8 Andar P, Macau
T +853 2870 2971
F +853 2870 2970
info.mo@zumtobelgroup.com

KOREA

ZG Lighting Hong Kong Ltd
official representative office
#1506, Union Center Building,
310, Gangnam road, Gangnam-gu,
Seoul 06253, Korea
T +82 2 565 8823 ext.4
F +82 2 565 8827
info.kr@zumtobelgroup.com

SINGAPORE AND THAILAND

ZG Lighting Singapore Pte Ltd
158 Kallang Way # 06-01/02
Singapore 349245
T +65 6844 5800
F +65 6745 7707
info.sg@zumtobelgroup.com

VIETNAM

ZG Lighting Singapore Pte. Ltd.
official representative office
215 Nam Ky Khoi Nghia Street,
Ward 7, District 3, HCMC
T +84 8 39320666
F +84 8 39320111
Info.vn@zumtobelgroup.com

CHINA

Thorn Lighting (Guangzhou) Limited
12A Lian Yun Road Eastern Section,
GETDD,
Guangzhou 510530, P.R. China
T +86 20 2232 6000
info.cn@zumtobelgroup.com

Thorn Lighting (Guangzhou) Limited
Shanghai Branch
Room 802, No.H Building,
No.142 Tianlin Road,
Shanghai 200233, P.R. China
T +86 21 6375 6699

Thorn Lighting (Guangzhou) Limited
Beijing Branch
Room 2101, Block B,
Jianwai SOHO East,
39 East 3rd Ring Road,
Chaoyang District,
Beijing 100022, P.R. China
T +86 10 6505 4601

Thorn Lighting (Guangzhou) Limited
Guangzhou Branch
23E, Sanxin Building, No. 33
Huangpu Road West, Tianhe District
Guangzhou 510620, P.R. China
T +86 20 8551 5759

Thorn Lighting (Guangzhou) Limited
Shenyang Branch
Room 2307, Block A, Green SOHO,
No.39 Shisan Wei Road, Heping District,
Shenyang 110003, P.R. China
T +86 24 2326 9168



5 YEAR
WARRANTY

As a globally leading luminaire manufacturer, Thorn Lighting provides a five-year warranty for its complete product range within all European Countries.
THORNLIGHTING.COM/WARRANTY

Thorn Lighting is constantly developing and improving its products. All descriptions, illustrations, drawings and specifications in this publication present only general particulars and shall not form part of any contract. The right is reserved to change specifications without prior notification or public announcement. All goods supplied by the company are supplied subject to the company's General Conditions of Sale, a copy of which is available on request. All measurements are in millimetres and weights in kilograms unless otherwise stated.
Publication Date: 04/18



www.pefc.org PEFC/6-38-214