

THORN

LIGHTING



BRAND NEW

PRODUCT FOCUS EDITION 1/2018

BRAND NEW PRODUCTS

INDOOR

OUTDOOR

AQUAFORCE PRO

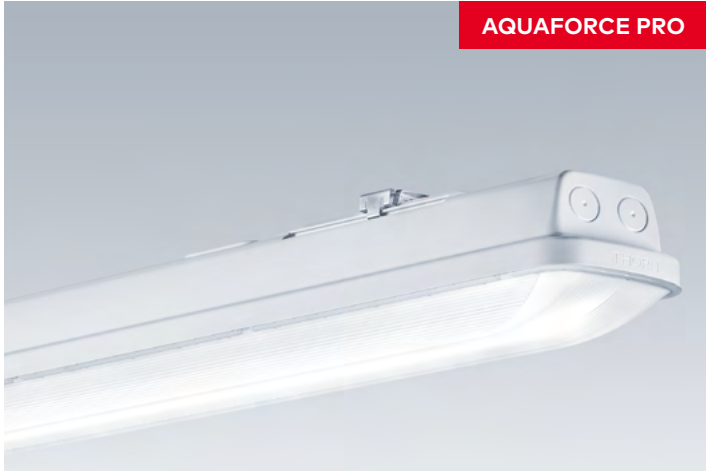

DUROLIGHT



EP 445



FEROZ



FLOW



ISARO PRO



Beginning of 2018 we're setting fresh standards for moisture-proof and dust-resistant LED lighting. Performance and versatility reach new heights with our Aquaforce Pro luminaire, while our brand-new Flow family takes outdoor lighting to the next level in terms of flexibility. The modular design of Flow makes it easy to provide the same look for different city spaces, empowering designers to achieve consistency and visual harmony in both new and retro-fit projects. The new robust high-performance LED street lantern Isaro Pro looks great on any road – and is also fit for the future. The outdoor portfolio will also be extended by EP445 an LED street lantern with that blends into historic cities and towns. Alternatively, EP445 offers the best of both worlds for those wanting to combine modern lighting technology with a more traditional look.

Designed for the toughest transport and industrial applications, our new Feroz effortlessly copes with heat, dust, moisture, impacts and more. Going one step further when it comes to resistance, the new Durolight is an extremely robust linear luminaire with the highest levels of anti-vandal and anti-ligature protection.

And, as always, we continue to update and improve our existing products to ensure the best possible performance. For details of all the latest additions to the Thorn range, please read on.



AQUA



Building on the success of Thorn's market-leading moisture proof luminaire, Aquaforce Pro sets a new standard for moisture and dust-resistant LED lighting.

FORCE PRO



When it comes to luminaires that can handle damp and dusty conditions, the name of Thorn Aquaforce is already well known. With the brand-new Aquaforce Pro, performance and versatility have reached new heights. The IP66-rated fitting is available in a choice of wide- and medium-beam light distribution options tailored for factory and warehouse settings or car parks. Its opal diffuser ensures the best light quality. Aquaforce Pro features DALI dimming and a built-in corridor function, using a presence/absence detector to dim down and turn off automatically when circulation areas are not in use. This robust

luminaire is built to resist ambient temperatures ranging from -20°C to 35°C , and its clever drip-edge design avoids dust depositing on the light output surface. Some LED luminaires still struggle to match the light output of conventional products on a one-for-one basis. But Aquaforce Pro comes in an 8000 lm version, powerful enough to serve as a direct one-for-one replacement for 2x58 W or 2x49 W conventional luminaires, making it an ideal choice for retrofit and refurbishment projects. And with efficacy as high as 141 lm/W, the potential savings are significant.



Durolight is an extremely robust linear luminaire with the highest in antivandal and antiligature protection.

Luminaires don't come any tougher than Durolight. This new fitting has been designed to withstand the toughest knocks and to be deployed in the most demanding settings. Available in a choice of shapes for wall, ceiling or corner mounting, Durolight is suitable for public spaces and custodial facilities, thanks to its antivandal and antiligature design. Built from 2 mm-thick sheet steel, Durolight carries the maximum IK10 rating for impact protection, and can withstand impacts of up to 170 joules – approximately eight times higher than is required by the standard. It is rated IP65 for protection against dust and moisture, and also boasts high UV resistance, contributing to a long lifetime when used outdoors. Fixed output and DALI versions of Durolight are available.



DURO LIGHT





EP 445

With historic style and cutting-edge lighting technology, EP445 brings you the very best of both worlds.

Thorn's EP445 combines a 19th-century look with 21st-century performance. This retro-style lantern is the perfect choice for replacing traditional lighting in historic locations and conservation areas with a durable, energy-efficient and modern solution. EP445 features an automatic disconnection to prevent electrical damage when the lantern is opened, and 10kV surge protection. Three different levels of current can be selected on the driver, for on-site adjustment. And this robust lantern is designed to withstand the

elements – it's rated IP66 for protection against dust and moisture, and IK08 for impact resistance. With efficacy of 122 lm/W and a 100 000-hour lifetime, EP445 is a particularly attractive choice for retrofit and refurbishment projects where energy saving is a priority. This is reinforced by integrated Bi-Power setups, which can be very easily adapted. EP445 offers a post-top and suspended versions, accessories for use with a variety of supports, and a wide choice of light distributions.

FEROZ



Designed for the toughest transport and industrial applications, Feroz effortlessly withstands heat, dust, moisture, impact and more.

Feroz is one of the toughest LED luminaires on the market. Designed to meet the requirements of demanding infrastructure applications such as railway stations, depots and bus shelters, Feroz also suits a range of other industrial settings. Employing the latest in LED technology and digital control, Feroz is ideal for new applications, or as a retrofit product to replace older lighting technologies. Available in standard lengths of 0.6, 1.2 and 1.5 metres, it's an easy product to retrofit in order to reduce maintenance and energy costs – and to introduce digital control – to existing installations. Feroz has a rated lifetime of 100000 hours to L70. This single product can handle all areas, all seasons and all applications.



FLOW



Our most versatile outdoor solution yet, Flow integrates seamlessly into any urban setting, allowing designers to create a unified look.



As people flow through the city by car, bike or on foot, Flow creates light that flows with them, adapting and providing safety and high visual performance, while creating a pleasant and welcoming ambience. Flow fits in everywhere, providing the most efficient distribution for all kinds of urban activities – whether it's jogging, driving, shopping or socialising. The timeless, understated design language of this brand new luminaire makes it easy to picture in setting. But it's not only Flow's appearance that makes it so flexible. The luminaire features 6 different mounting variants, 13 optical possibilities for street lighting and area lighting, a choice of tilting options (negative and positive) and dimming options to contribute to comfort and wellbeing in large and small roads, residential areas, city centres, car parks, footpaths, train platforms, education and sports institutions, industrial buildings and open areas. Compatible with most of radio frequency systems on the market, Flow also brings intelligence to urban spaces through a wide choice of control options, including DALI, bi-power, power-line control and presence detection. This enables energy savings while improving safety and contributing to a sense of wellbeing by adapting to movements of pedestrians, cyclists and cars. Flow offers high-performance photometry optimised for each specific application. Its efficacy reaches 139 lm/W, enabling it to save significant amounts of energy compared to conventional solutions, and it comes with a 10 kV surge protection device as standard. Lumen packages ranging from 1700 lm to 13600 lm are available.





ISARO PRO

This robust and high-performance LED street lantern brings comfort and safety to any road or street.

Pressure to reduce energy costs and carbon emissions for outdoor lighting is stronger than ever. High-quality LED street lanterns offer a great solution, thanks to clever design, highly efficient light sources, long life and smart controls. Made of top-quality alloy, Isaro Pro is built to withstand all conditions, and to cope with physical impact and vibration. With a lifetime of up to 100 000 hours, it guarantees years of reliable performance, ensuring a low-cost of ownership. And with connectivity built in, it's a truly futureproof solution. As well

as being robust, this modern lantern is slim, sleek and performs brilliantly. With light output of up to 9500 lm for the first size launched, Isaro Pro size S is powerful enough to handle streets, residential areas and car parks. Because every street is different, Isaro Pro uses Thorn's unique R-PEC[®] optic to offer unprecedented optical flexibility. A choice of 14 precise light distributions is available for highly efficient and comfortable light, exactly where it is needed, whether lighting a residential street, a busy road or a pedestrian crossing.

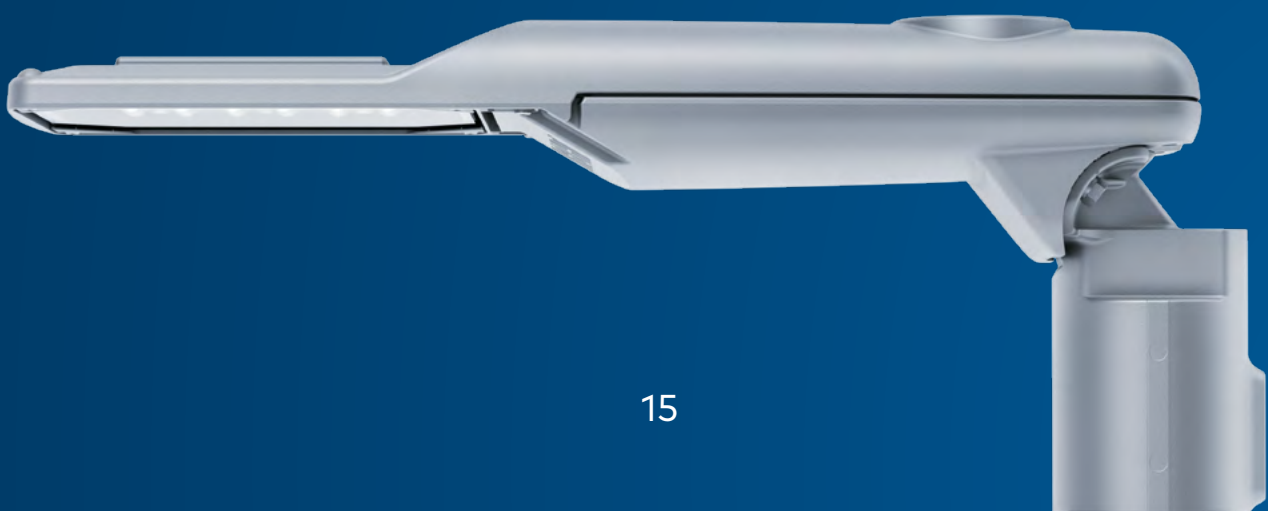

PRODUCT UPGRADES



THORNLIGHTING.COM/POPL

POPPACK

A classic that remains as popular as ever, the latest Thorn PopPack provides enhanced flexibility.

PopPack is the perfect one-for-one LED replacement for single and twin fluorescent battens, enabling big savings on energy and maintenance. It's suitable for refurbishment and new installations, with a choice of three lengths and eight lumen outputs of up to 11000 lm. With a DALI dimmable version available and PIR sensors, further savings can be achieved. It's easy to install and align, using the slots in the base tray, either directly on to the surface or using a BESA box. PopPack's multiple rear cable entries and knock-out side cable entries ensure simple electrical connection and it is suitable for through-wiring. PopPack features a built-in three-hour emergency function.



THORNLIGHTING.COM/GLCL

GLACIER II LED

With its high output of 9500 lumen, this new variation on our pendant luminaire is perfect for applications with high ceilings.

Our Glacier II LED range has extended to include a new 9500 lm version, ideal for retail applications with mounting heights of five metres or higher. Glacier II LED is a highly efficient decorative modern LED pendant luminaire. Available with a grey or black body and a choice of diffusers, its design makes it the perfect complement to other products in Thorn's retail portfolio. And the increased lumen package of 9500 lm makes Glacier II LED a perfect one-for-one replacement for traditional 150 W HID pendant fittings. Installation is quick and easy thanks to a bayonet-style diffuser mounting and 2.5-metre suspension cable with quick-lock.



THORNLIGHTING.COM/R2L2

R2L2

A complete road lantern family at the forefront of LED technology to offer excellent lighting performance and cover all applications.

Sleek, modern and consistent, R2L2 is easy to integrate into the landscape and has a balanced design from all angles. Simply choose the luminaire size and quantity and type of light distribution. R2L2 uses a high performance R-PEC® optic to offer 14 types of light distribution for precise light placement with no waste light. Use R2L2 to efficiently and effectively light all road applications, from high speed roads to pedestrian crossings thanks to its lumen output up to 31000 lm. R2L2 offers a wide range of optional control solutions to meet all needs and environments. As well as maximising energy savings by reducing waste energy, R2L2's lighting controls will extend the LED lifetime and in turn, reduce maintenance requirements. R2L2 benefits from an attractive integrated all-in-one spigot.



THORNLIGHTING.COM/CTEQ

CIVITEQ

The perfect balance between cost of ownership and performance for road lighting

CivITEQ is an unobtrusive, cost-effective road lighting solution that's ideal for refurbishment projects. And increased luminous efficacy makes it more economical to run than ever. Fitted with our unique R-PEC® optic, CivITEQ enables 14 precise light distributions, bringing safe and efficient light (up to 152 lm/W) to a wide variety of residential streets and high traffic roads. It is available in three sizes with light output of up to 40330 lm, and with versatile installation possibilities to suit any installation layout. Options and accessories include 10kV surge protection device, automatic disconnection, BPS, LRT, photocell and external louvres. CivITEQ's compact and lightweight design make for easy handling and installation, and its long-life keeps maintenance costs low.

THORN

LIGHTING

AUSTRALIA

NSW – Headquarters
ZG Lighting Australia Pty Ltd
2/7 Millner Avenue,
Horsley Park,
NSW 2175 Australia
T +61 1300 139 965
info.au@zumtobelgroup.com
zumtobelgroup.com

NSW – Sales office
ZG Lighting Australia Pty Ltd
38 Oxley Street
Crows Nest, NSW 2065
Australia
T +61 1300 139 965
info.au@zumtobelgroup.com
zumtobelgroup.com

VIC
ZG Lighting Australia Pty Ltd
163 Epsom Road
Flemington, VIC 3031
Australia
T +61 1300 139 965
info.au@zumtobelgroup.com
zumtobelgroup.com

QLD
ZG Lighting Australia Pty Ltd
Level 1, 349 Coronation Drive
Milton, 4064 QLD
Australia
T +61 1300 139 965
info.au@zumtobelgroup.com
zumtobelgroup.com

WA
SCOPE LIGHTING PTY. LTD.
14 Christable Way
Landsdale, WA 6065
Australia
T +61 1300 139 965
info.au@zumtobelgroup.com
zumtobelgroup.com

SA
LEDA Lighting Solutions PTY. LTD.
3 Prescott Court
Hallett Cove, SA 5158
Australia
T +61 1300 139 965
info.au@zumtobelgroup.com
zumtobelgroup.com

TAS
Westport Agencies PTY. LTD.
12 Fleet Street
Moonah, TAS 7009
Australia
T +61 1300 139 965
info.au@zumtobelgroup.com
zumtobelgroup.com

NT
Global Lighting Solutions PTY. LTD.
Cnr Mataram St & Coonawarra Rd
Winnellie, NT 0820
Australia
T +61 1300 139 965
info.au@zumtobelgroup.com
zumtobelgroup.com

NEW ZEALAND

AUCKLAND - Headquarters
ZG Lighting (NZ) Limited
27 Jomac Place,
Avondale, Auckland 1026
New Zealand
T 0800 800 834
T +64 (9) 828 7155
F +64 (9) 828 7591
info.nz@zumtobelgroup.com
zumtobelgroup.com

WELLINGTON
ZG Lighting (NZ) Limited
Level 2, 225 Thorndon Quay,
Pipitea, Wellington 6011
New Zealand
T 0800 800 834
T +64 04 815 8010
F +64 04 499 6058
info.nz@zumtobelgroup.com
zumtobelgroup.com

CHRISTCHURCH
ZG Lighting (NZ) Limited
Unit 7A, 303 Blenheim Rd
Upper Riccarton, Christchurch 8041
New Zealand
T 0800 800 834
T +64 03 366 2485
F +64 03 366 8905
info.nz@zumtobelgroup.com
zumtobelgroup.com



**5 YEAR
WARRANTY**

As a globally leading luminaire manufacturer, Thorn Lighting provides a five-year warranty for its complete product range within all European Countries.
THORNLIGHTING.COM/WARRANTY

Thorn Lighting is constantly developing and improving its products. All descriptions, illustrations, drawings and specifications in this publication present only general particulars and shall not form part of any contract. The right is reserved to change specifications without prior notification or public announcement. All goods supplied by the company are supplied subject to the company's General Conditions of Sale, a copy of which is available on request. All measurements are in millimetres and weights in kilograms unless otherwise stated.
Publication Date: 04/18



www.pefc.org PEFC/6-38-214