

A new, highly durable IP65 luminaire for use in wet and dusty environments, where reliability and peace of mind are important

AquaForce II is a cost effective range of highly durable IP65 fluorescent fittings. Its features include easy quick-fix installation brackets with every luminaire, sturdy polycarbonate body and diffuser for maximum impact resistance, and a choice of Switchstart, High Frequency and emergency control gear.

All luminaires are made in a highly automated manufacturing process, ensuring a consistent, seamless gasket seal set into a deep channel, giving you peace of mind that AquaForce II will hold its performance in tough IP65 environments.

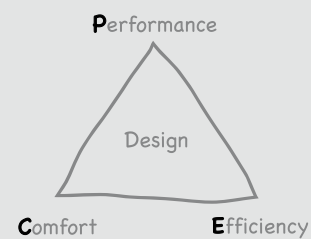

Performance: High light output. Eliminates glare

Efficiency: Quick to install with choice of accessories. Easy to maintain. Efficient lm/W IP65. ENEC approval

Comfort: Heightens safety and comfort. Reassuring seal

THORN

Lighting people and places

Thorn Lighting Main Offices

Australia
Thorn Lighting Pty Limited
43 Newton Road,
Wetherill Park NSW 2164
Tel: (02) 9604 4300
Fax: (02) 9604 4588
E-mail: info@thornlight.com.au
Website: www.thornlight.com.au

Austria
Thorn Licht GmbH
Donau-City-Straße 11, 1220 Wien, Austria
Tel: (43) 1 202 66 11
Fax: (43) 1 202 66 11 12
E-mail: office@thorn.at

China
Thorn Lighting (Guangzhou) Operations Ltd
No.12 Lian Yun Road, Eastern Section, GETDD,
Guangzhou 510760, China
Tel: (86) 20 3228 2706
Fax: (86) 20 3228 1777
E-mail: sales@thorn.com.cn

Thorn Lighting (Tianjin) Co. Ltd
332 Hongqi Road, Tianjin 300190, China
Tel: (86) 22 8369 2303
Fax: (86) 22 8369 2302
E-mail: marketing@thornij.com.cn

Czech Republic
Thorn Lighting CS spol. s.r.o.,
Na Březince 6/930, 150 00 Praha 5
Czech Republic
Tel: (420) 224 315 252
Fax: (420) 233 326 313
E-mail: thorn@thornlight.cz
Website: www.thornlight.cz

Denmark
Thorn Lighting A/S
Albuén 44, 6000 Kolding, Denmark
Tel: (45) 7696 3600
Fax: (45) 7696 3601
Website: www.thornlight.dk

France
Thorn Europhane SA
156 Boulevard Haussmann,
Cedex 08, Paris 75379, France
Tel: (33) 1 49 53 6262
Fax: (33) 1 49 53 6240
Website: www.thorn.fr

Hong Kong
Thorn Lighting (Hong Kong) Limited
Unit 4301, Level 43, Tower 1, Metroplaza,
223 Hing Fong Road, Kwai Chung, N.T.,
Hong Kong, China
Tel: (852) 2578 4303
Fax: (852) 2887 0247
E-mail: info@thorn.com.hk
Website: www.thorn.com.hk

Ireland
Thorn Lighting (Ireland) Limited
320 Harold's Cross Road, Dublin 6W, Ireland
Tel: (353) 1 4922 877
Fax: (353) 1 4922 724
E-mail: enq.dublin@thornlight.com

Italy
Thorn Europhane Spa
Via G Di Vittorio, 2, Cadrano di Granarolo,
Bologna 40057, Italy
Tel: (39) 051 763391
Fax: (39) 051 763088
E-mail: info@thornlighting.it
Website: www.thornlighting.it

New Zealand
Thorn Lighting (NZ) Ltd
399 Rosebank Road, P O Box 71134, Rosebank,
Auckland 7, New Zealand
Tel: (64) 9 828 7155
Fax: (64) 9 828 7591

Norway
Thorn Lighting AS
Strømsveien 344, 1081 Oslo, Norway
Tel: (47) 22 82 07 00
Fax: (47) 22 82 07 01
E-mail: info@thornlight.no
Website: www.thornlighting.no

Poland
Thorn Lighting Polska Sp.z o.o.,
Ul. Gazowa 26A, Wrocław 50-513, Poland
Tel: (48) 71 7833 740
Fax: (48) 71 3366 029
E-mail: thorn@thornlight.pl
Website: www.thornlight.pl

Russia
Thorn Lighting
Novoslobodskaya Str., 21, office 406 Business Center
"Novoslobodskaya 21", Moscow 127030, Russia
Tel: (7) 495 981 35 41
Fax: (7) 495 981 35 42
E-mail: office.moscow@thorn.ru
Website: www.thorn.ru

Singapore
Thorn Lighting (Singapore) Pte Ltd
5 Kaki Bukit Crescent, 04-02 Kayotech Building,
416238 Singapore
Tel: (65) 6844 5800
Fax: (65) 6745 7707
E-mail: info@thornlight.com.sg
Website: www.thornlight.com.sg

Sweden
Thorn Lighting AB
Industrigatan, Box 305,
SE-261 23 Landskrona, Sweden
Tel: (46) 418 520 00
Fax: (46) 418 265 74
E-mail: thorn@thornlight.se
Website: www.thornlight.se

United Arab Emirates
Thorn Lighting Ltd Dubai
Al Shoala Building, Office 301, Block E,
Airport road, P.O. Box 1200,
Deira, Dubai, UAE
Tel: (971) 4 2940181
Fax: (971) 4 2948838
E-mail: tluae@emirates.net.ae

Thorn Gulf LLC
Al Shoala Building, Office 301/2, Block E,
Airport road, P.O. Box 22672,
Deira, Dubai, UAE
Tel: (971) 4 2948938
Fax: (971) 4 2948838
E-mail: thorg@emirates.net.ae

United Kingdom
Thorn Lighting Limited
Silver Screens, Elstree Way,
Borehamwood, Hertfordshire, WD6 1FE, UK
Tel: (44) 20 8732 9800
Fax: (44) 20 8732 9801
E-mail: brochures@thornlight.com
Website: www.thornlighting.co.uk

International Sales
Thorn Lighting Limited
Silver Screens, Elstree Way, Borehamwood,
Hertfordshire, WD6 1FE, UK
Tel: (44) 20 8732 1915
Fax: (44) 20 8732 1911
E-mail: international_sales@thornlight.com

www.thornlighting.com



Simple to order:

- Luminaire comes with Quick-fix brackets as standard

Rapid installation:

- Quick-fix bracket
- Simple push to fit toggles
- Clip in gear tray
- High-speed 'Connect' versions available



High protection:

- Robust polycarbonate material
- High quality IP65 seal
- Tamper resistant stainless steel toggles available

Thorn Lighting is constantly developing and improving its products. All descriptions, illustrations, drawings and specifications in this publication present only general particulars and shall not form part of any contract. The right is reserved to change specifications without prior notification or public announcement. All goods supplied by the company are supplied subject to the company's General Conditions of Sale, a copy of which is available on request. All measurements are in millimetres and weights in kilograms unless otherwise stated.

Publication No: 405 (INT) Publication Date: 06/07

THORN

AquaForce II

A new statement in reliable, value for money IP65 luminaires



Applications

Our tough, polycarbonate body maximises vandal resistance in IP65 luminaires. Together with lighter weight, fast-fit components and connectors, AquaForce II is also easier to fit than ever before.



General building areas

- Under canopies
- Car parks
- Changing rooms
- Corridors
- Kitchens*
- Showers
- Sports stadia
- Toilets
- Pedestrian tunnels
- Agricultural buildings*

Industrial areas

- Abattoirs*
- Factories*
- Garages
- Process areas*
- Warehouses
- Boiler rooms
- Loading bays
- Plant rooms*
- Transport terminals*

* Consider chemical resistance information before specification

Chemical Resistance

AquaForce II is suitable for environments subject to prolonged exposure to the following chemical types and chemical compounds:

Chemical type	Chemical compounds
Inorganic acids:	Nitric (<10%); sulphuric (<20%); hydrochloric (<10%); chromic (<20%); phosphoric (<10%);
Inorganic salts:	Marine salts; copper sulphate; soda lime
Organics (Aliphatics):	Ethanol (alcohol); methanol (alcohol); propanol (alcohol); Methane (paraffin gas); propane (paraffin gas); formaldehyde (formalin); formic acid; stearic acid (soap); urea; ethylene glycol (anti-freeze); glucose (sugar)
Organics (aromatics):	Glycerol (glycerine)
Foodstuffs, drinks and cooking products:	Milk, fruit juices; vegetable oils (olive, sunflower, soya)*; meats (beef, lamb, pork, poultry); fish; cooking fats; alcoholic beverages (beers); carbonated beverages (lemonade); wines and spirits; water; vinegar
Gases:	Ozone; sulphur dioxide (industrial pollutant)
Building materials and paints:	Emulsion (water base); cement
Oils, fats and fuels:	Animal (not pork); silicone, petrol (paraffin); diesel
Disinfectants:	Hydrogen peroxide (40%); sodium hypochlorite (10%)
Cleaning agents:	Soaps

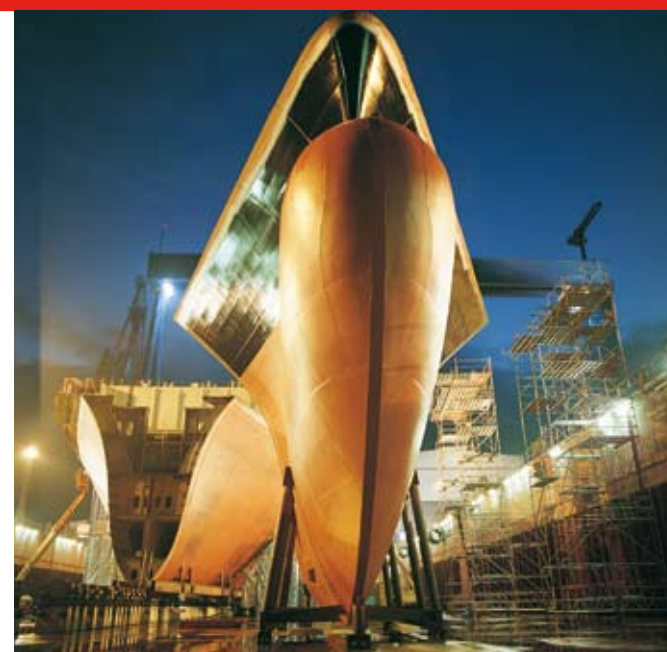

Product details



1.



2.



3.



4.



5.



6.



7.



8.



9.

Lamps

□: 36-58W T26 (FD) linear fluorescent. Cap: G13

Materials/Finish

Canopy and diffuser: injection moulded fire retardant polycarbonate.
Gear tray: sheet steel, white enamel finish
Toggles: polycarbonate (stainless steel available).

Installation/Mounting

Cable entry positions at the back and each end of the fitting.
Stainless steel quick-fix brackets supplied with each luminaire.
Connect versions available with fast electrical connection facility.
Conduit box mounting, chain suspension, conduit suspension and catenary suspension kits, plus through wire kits are all available (see accessories listing)

Standards

Designed and manufactured to comply with EN 60598.
⊕ Class I Electrical - earthed metalwork
850°C Fire retardant
6N/M Impact resistant
⚡ IP65 ⚡ CE

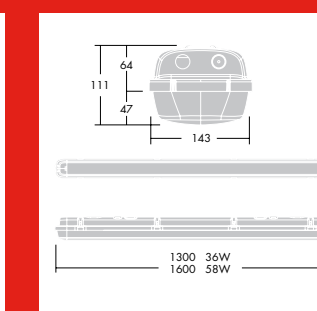
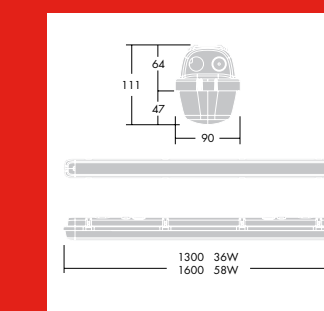

Ordering Guide

Lamp(s) to be ordered separately [Except for connect versions].

Description	Ilcos Code	Socket	Weight Kg	SAP code	Description	Ilcos Code	Socket	Weight Kg	SAP code
Non compensated switchstart versions					Switchstart Connect versions				
AQUAF2 1x36W T26 NC NL	FD	G13	2	96503022	AQUAF2 1x36W T26 CP CON U840	FD	G13	2	96503039
AQUAF2 1x58W T26 NC NL	FD	G13	2.7	96503045	AQUAF2 1x58W T26 CP CON U840	FD	G13	2.7	96503062
AQUAF2 2x36W T26 NC NL	FD	G13	3.1	96503091	AQUAF2 2x36W T26 CP CON U840	FD	G13	3.1	96503108
AQUAF2 2x58W T26 NC NL	FD	G13	4.3	96503114	AQUAF2 2x58W T26 CP CON U840	FD	G13	4.3	96503131
Switchstart versions					High frequency Connect versions				
AQUAF2 1x36W T26 CP NL	FD	G13	2	96503020	AQUAF2 1x36W T26 HF CON U840	FD	G13	1.7	96503041
AQUAF2 1x58W T26 CP NL	FD	G13	2.7	96503043	AQUAF2 1x58W T26 HF CON U840	FD	G13	2.3	96503064
AQUAF2 2x36W T26 CP NL	FD	G13	3.1	96503089	AQUAF2 2x36W T26 HF CON U840	FD	G13	2.3	96503110
AQUAF2 2x58W T26 CP NL	FD	G13	4.3	96503112	AQUAF2 2x58W T26 HF CON U840	FD	G13	2.9	96503133
High frequency versions									
AQUAF2 1x36W T26 HF NL	FD	G13	1.7	96503024					
AQUAF2 1x58W T26 HF NL	FD	G13	2.3	96503047					
AQUAF2 2x36W T26 HF NL	FD	G13	2.3	96503093					
AQUAF2 2x58W T26 HF NL	FD	G13	2.9	96503116					

Accessories

Description		SAP code
FORCE2 28/36 TW KIT	AQUAFORCE II 28/36 through wire kit	96503163
FORCE2 35/49/58 TW KIT	AQUAFORCE II 35/49/58 through wire kit	96503164
FORCE2 FIX KIT	AQUAFORCE II quick fix bracket (pair)	96503166
FORCE2 FIX/CH KIT	AQUAFORCE II chain suspension kit (10 pairs)	96503167
FORCE2 BESA KIT	AQUAFORCE II besa box installation kit (pair)	96503168
FORCE2 MRS KIT	AQUAFORCE II conduit kit (pair)	96503169
FORCE2 MCA KIT	AQUAFORCE II Catenary suspension kit (pair)	96233817
FORCE2 28/36 RS CLIP KIT	AQUAFORCE II 28/36 tamper resistant stainless steel toggle kit	96503157
FORCE2 35/49/58 RS CLIP KIT	AQUAFORCE II 35/49/58 tamper resistant stainless steel toggle kit	96503158
FORCE2 28/36 PC CLIP KIT	AQUAFORCE II 28/36 polycarbonate toggle kit	96503160
FORCE2 35/49/58 PC CLIP KIT	AQUAFORCE II 35/49/58 polycarbonate toggle kit	96503161

1. Cable entries
2. Quick-fix bracket installed to ceiling
3. Quick-fix bracket installed to fitting
4. Deep channel and excellent gasket seal
5. Opening toggle
6. Gear tray clips into place
7. Gear tray in place
8. Through wire kit
9. Tamper resistant stainless steel toggles