

Voyager Blade 2

THORN

96636567 VOYAGER BLADE 2 150 CON E3BC WH

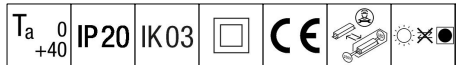

Voyager Blade 2

LED Escape sign luminaire; Luminaire with local battery supply for 3h emergency lighting in maintained or non-maintained mode with integrated radio module basicDim Wireless (Casambi) for wireless communication with central monitoring system, display of luminaire status via status LED; housing made of polycarbonate white (RAL 9016), injection moulded; luminaire easy to install; supplied with a set of ISO 7010 mountable direction signs (left, right, up, down and blank) for viewing from a maximum distance of 30 m; zero maintenance thanks to LED technology; service life of 50,000 h at constant luminous flux; uniform backlighting of pictogram; luminance > 500 cd/m² in the white region. Power supply: 220/240 V AC; Luminaire input power: 6.1 W; degree of protection: IP20, class of protection: Class II electrical; Impact strength: IK03; ambient temperature: 5°C to +40°C dimensions of luminaire including escape sign: Dimensions: 330 x 45 x 375 mm; weight: 1.3 kg

Self-contained emergency luminaires rely on long-lasting batteries. Voyager Blade 2's high-tech battery is robust and comes with a three-year guarantee (applicable subject to the terms and conditions of and to the extent as set forth in the manufacturer's guarantee on Thorn products, which shall be applicable analogously and which is available under http://www.thornlighting.com/en/products/5-year-guarantee/5-year-warranty/terms-of-guarantee_en.pdf. The battery guarantee shall not come into effect if the product has been installed later than three(3) months after delivery EXW (Incoterms 2010).



TLG_VOB2_F_150_UP_CONTUS.jpg

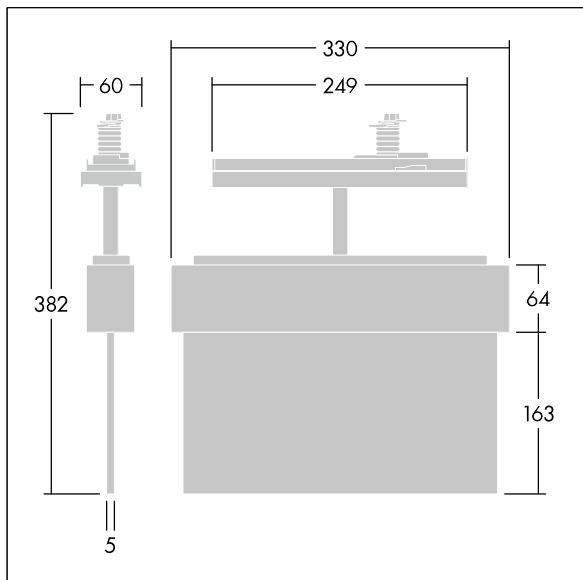

TLG_VOB2_M_150_CONTUS.wmf

All values marked with an * are rated values. Unless stated otherwise, the values apply to an ambient temperature of 25°C.

Thorn Lighting is constantly developing and improving its products. The right is reserved to change specifications without prior notification or public announcement.
© Thorn Lighting